

11. CLUTCH/GEARSHIFT LINKAGE

| | | | |
|-------------------------------------|------|---|-------|
| COMPONENT LOCATION | 11-2 | GEARSHIFT LINKAGE | 11-15 |
| SERVICE INFORMATION | 11-4 | PRIMARY GEARS | 11-18 |
| TROUBLESHOOTING | 11-5 | RIGHT CRANKCASE COVER INSTALLATION | 11-23 |
| RIGHT CRANKCASE COVER REMOVAL | 11-6 | CLUTCH LIFTER ARM | 11-24 |
| CLUTCH | 11-6 | | |

CLUTCH/GEARSHIFT LINKAGE COMPONENT LOCATION

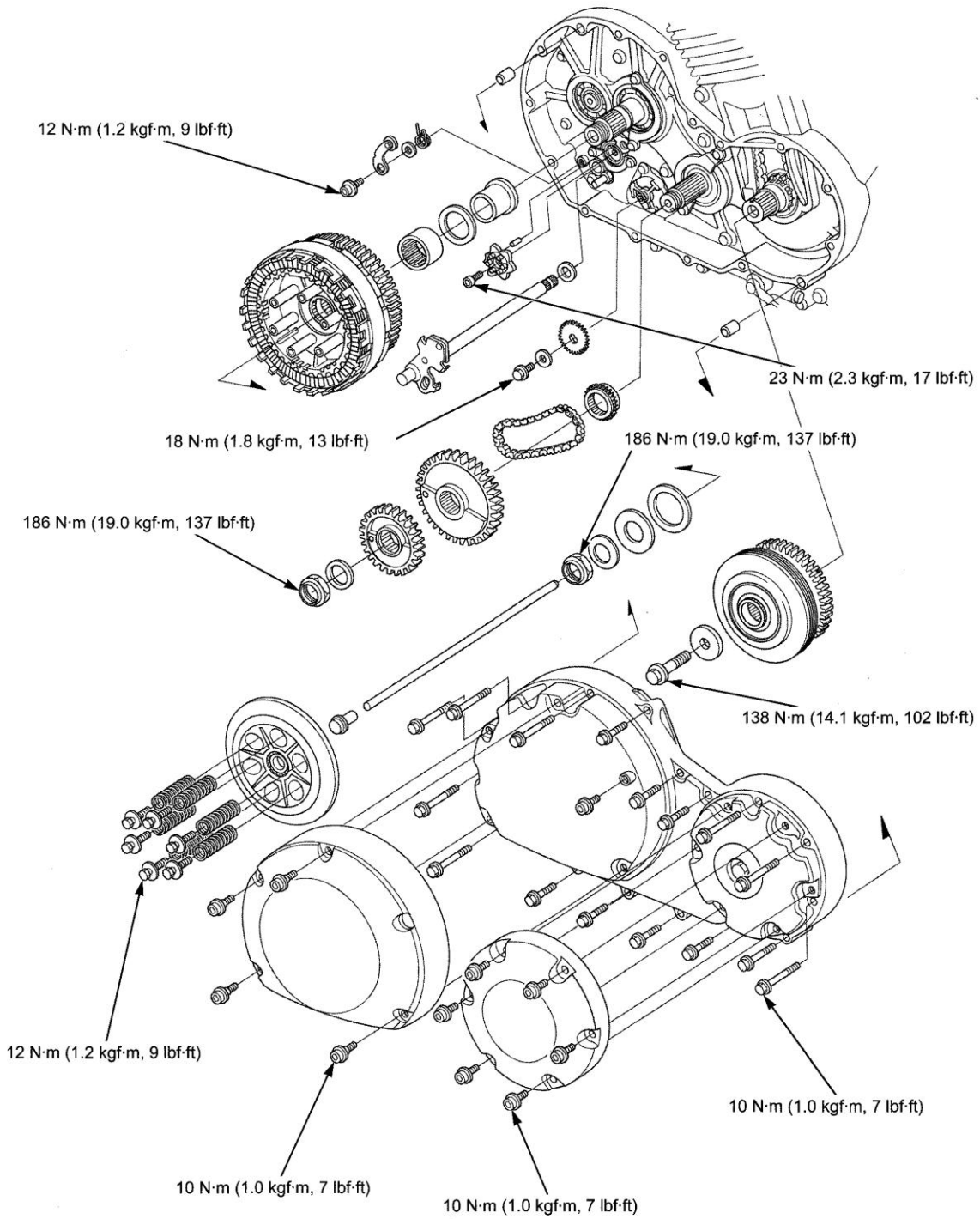

CLUTCH/GEARSHIFT LINKAGE

SERVICE INFORMATION

GENERAL

- This section covers service of the clutch, gearshift linkage, primary gears and clutch lifter arm. All service can be done with the engine installed in the frame.
- Engine oil viscosity, oil level and the use of oil additives have an effect on clutch disengagement. Oil additives of any kind are specifically not recommended. When the clutch does not disengage or the motorcycle creeps with the clutch disengaged, inspect the engine oil and oil level before servicing the clutch system.
- The crankcase must be separated when the transmission, shift drum and shift forks require service (page 13-7).

SPECIFICATIONS



Unit: mm (in)

| ITEM | STANDARD | SERVICE LIMIT |
|--|-----------------------------------|-----------------------------|
| Clutch lever freeplay | 10 – 20 (3/8 – 13/16) | – |
| Clutch | Spring free length | 58.2 (2.29) |
| | Disc thickness | 3.72 – 3.88 (0.146 – 0.153) |
| | Plate warpage | – |
| Clutch outer guide I.D. | 27.995 – 28.012 (1.1022 – 1.1028) | 28.03 (1.104) |
| Mainshaft O.D. at clutch outer guide | 27.980 – 27.993 (1.1016 – 1.1021) | 27.97 (1.101) |
| Clutch outer guide-to-mainshaft clearance | 0.002 – 0.032 (0.0001 – 0.0013) | 0.06 (0.002) |
| Clutch outer I.D. | 42.005 – 42.030 (1.6537 – 1.6547) | 42.05 (1.656) |
| Clutch outer needle bearing O.D. | 41.989 – 42.000 (1.6531 – 1.6535) | 41.98 (1.653) |
| Clutch outer-to-outer needle bearing clearance | 0.005 – 0.041 (0.0002 – 0.0016) | 0.07 (0.003) |

TORQUE VALUES

| | | |
|-----------------------------------|----------------------------------|---|
| Right crankcase cover bolt | 10 N·m (1.0 kgf·m, 7 lbf·ft) | |
| Clutch pressure plate bolt | 12 N·m (1.2 kgf·m, 9 lbf·ft) | |
| Clutch center lock nut | 186 N·m (19.0 kgf·m, 137 lbf·ft) | Lock nut; replace with a new one and stake. Apply engine oil to the threads and seating surface. |
| Clutch cover socket bolt | 10 N·m (1.0 kgf·m, 7 lbf·ft) | |
| Timing hole cap cover socket bolt | 10 N·m (1.0 kgf·m, 7 lbf·ft) | |
| Primary drive gear bolt | 138 N·m (14.1 kgf·m, 102 lbf·ft) | Apply engine oil to the threads. |
| Primary driven gear lock nut | 186 N·m (19.0 kgf·m, 137 lbf·ft) | Lock nut; replace with a new one and stake. Apply engine oil to the threads and seating surface. |
| Shift drum stopper arm pivot bolt | 12 N·m (1.2 kgf·m, 9 lbf·ft) | |
| Shift drum cam plate socket bolt | 23 N·m (2.3 kgf·m, 17 lbf·ft) | Apply locking agent to the threads. |
| Oil pump driven sprocket bolt | 18 N·m (1.8 kgf·m, 13 lbf·ft) | Apply locking agent to the threads. |

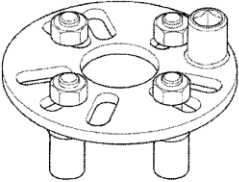
TOOLS

| | | |
|--|--|--|
| Clutch center holder 07JMB-MN50302  | Attachment, 32 x 35 mm 07746-0010100  | Pilot, 17 mm 07746-0040400  |
| or 07HGB-001010B (plate) and 07HGB-001020B (collar) (U.S.A. only) | | |

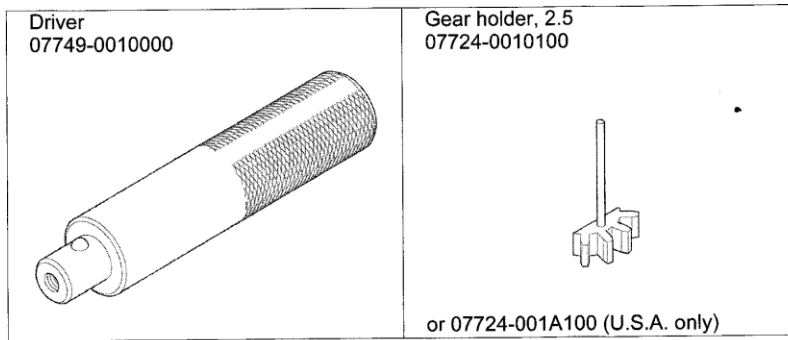

TROUBLESHOOTING

Clutch lever is too hard to pull in

- Damaged, kinked or dirty clutch cable
- Improperly routed clutch cable
- Damaged clutch lifter mechanism
- Faulty clutch lifter bearing
- Clutch lifter piece installed improperly

Clutch will not disengage or motorcycle creeps with clutch disengaged

- Too much clutch lever freeplay
- Warped clutch plates
- Loose clutch lock nut
- Engine oil level too high
- Improper oil viscosity or oil additive used
- Damaged clutch lifter mechanism
- Clutch lifter piece installed improperly
- Worn clutch outer slot and clutch center grooves
- Improper clutch operation (page 4-24)

Clutch slips when accelerating

- No clutch lever freeplay
- Worn clutch disc
- Weak clutch spring
- Clutch lifter sticking
- Engine oil level too low or oil additive used

Hard to shift

- Improper clutch operation (page 4-24)
- Incorrect engine oil viscosity
- Incorrect clutch adjustment
- Bent or damaged gearshift spindle
- Damaged shift drum cam plate
- Loose shift drum cam plate socket bolt
- Loose gearshift spindle pin
- Damaged gearshift spindle pin
- Loose shift drum stopper arm pivot bolt
- Damaged shift drum stopper arm

Transmission jumps out of gear

- Broken shift drum stopper arm
- Weak or broken gearshift spindle return springs
- Worn or damaged gearshift cam
- Loose shift drum cam plate bolt
- Damaged shift drum cam plate
- Broken gearshift spindle return spring

Gearshift pedal will not return

- Weak or broken gearshift spindle return spring
- Bent gearshift spindle

CLUTCH/GEARSHIFT LINKAGE

RIGHT CRANKCASE COVER REMOVAL

Drain the engine oil (page 4-13).
Remove the exhaust system (page 3-10).

Remove the socket bolts, clutch cover and timing hole cap cover.

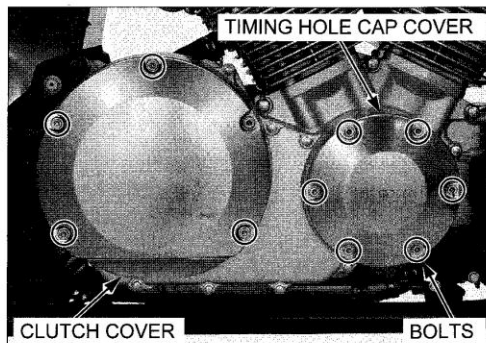

Loosen the bolts in a crisscross pattern in several steps and remove them.

Remove the right crankcase cover.

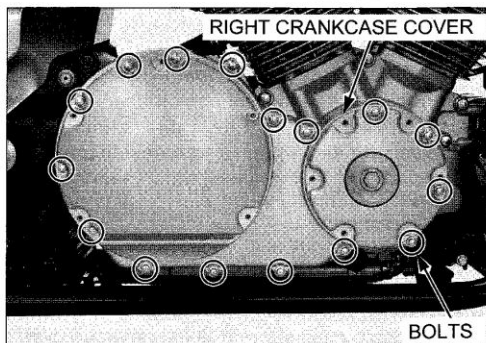

Be careful not to damage the mating surface.

Remove the dowel pins.

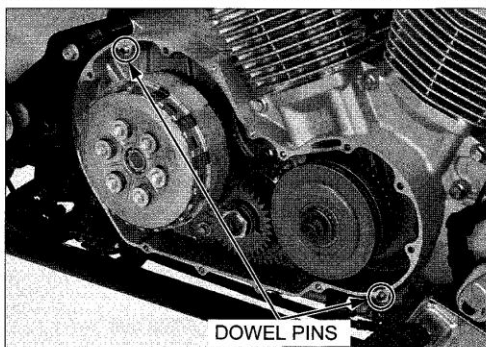

CLUTCH

REMOVAL

Remove the right crankcase cover (page 11-6).

Loosen the clutch pressure plate bolts in a crisscross pattern in several steps and remove the bolts, springs and clutch pressure plate.

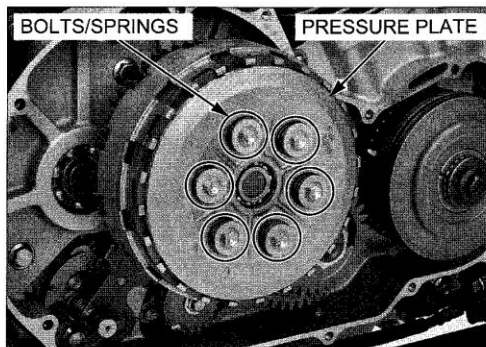

CLUTCH/GEARSHIFT LINKAGE

Remove the clutch joint piece and lifter rod from the mainshaft.

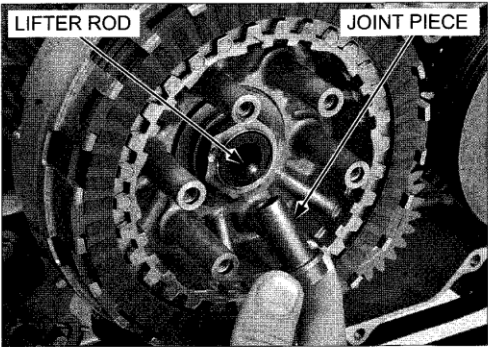

Remove the following:

- Clutch disc B
- Clutch plates
- Clutch discs A
- Clutch disc B

NOTE:

- When removing the clutch discs, note the number of the clutch discs A and B.

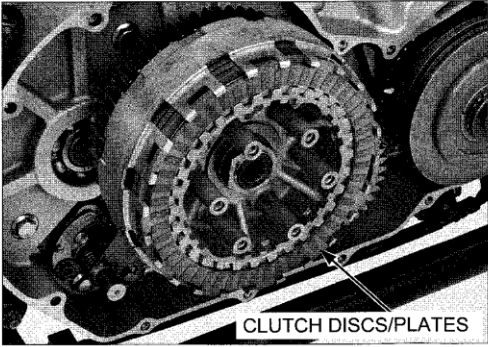

Be careful not to damage the mainshaft threads. Unstake the clutch center lock nut.

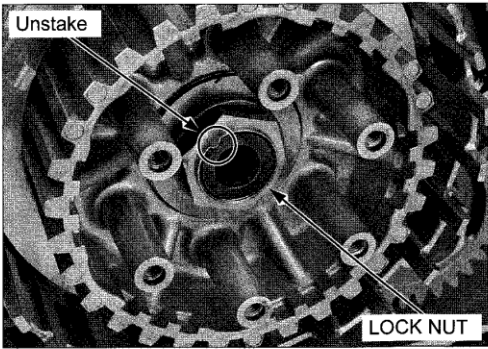

Hold the clutch center with the special tool and loosen the clutch center lock nut.

TOOL:

- Clutch center holder** 07JMB-MN50302 or
07HGB-001010B
(plate) and
07HGB-001020B
(collar) (U.S.A. only)

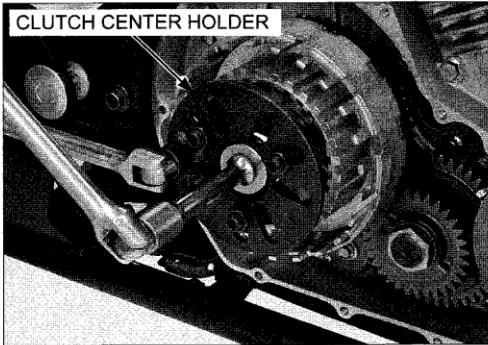

Remove the special tool and clutch center lock nut.

CLUTCH/GEARSHIFT LINKAGE

Remove the washers.

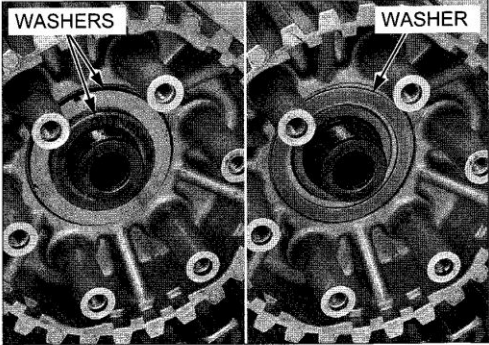

Remove the clutch center assembly.

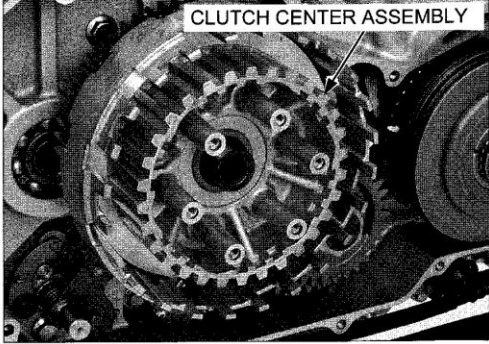

Remove the clutch center boss and rubber dampers from the clutch center.

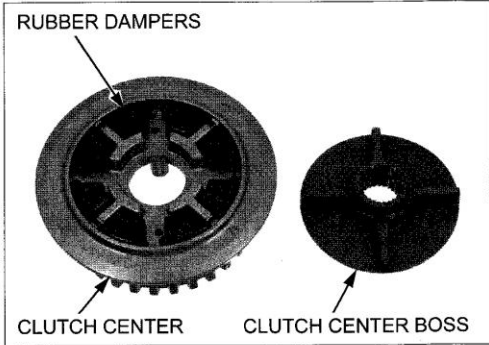

Remove the clutch outer.

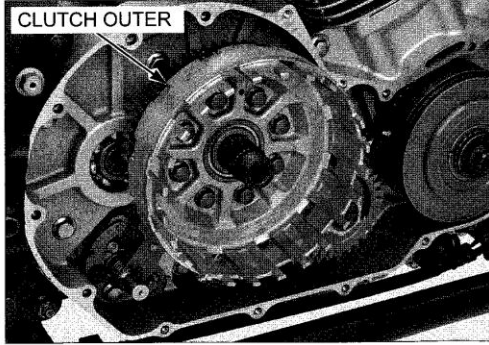

CLUTCH/GEARSHIFT LINKAGE

Remove the clutch outer needle bearing and outer guide washer.

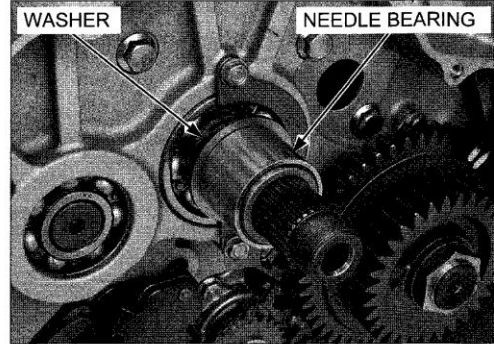

Remove the clutch outer guide.

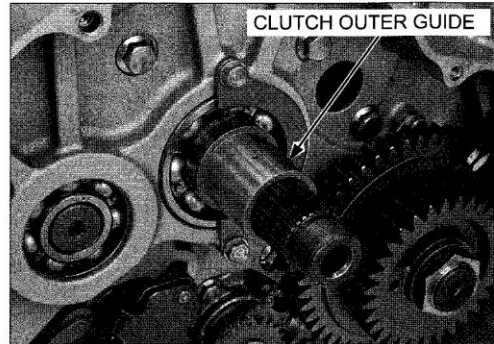

INSPECTION

LIFTER BEARING

Turn the inner race of the lifter bearing with your finger. The bearing should turn smoothly and quietly. Also check that the outer race fits tightly in the pressure plate.

Replace the bearing if the inner race does not turn smoothly and quietly, or if the outer race fit loosely in the pressure plate.

Drive out the bearing from the pressure plate.

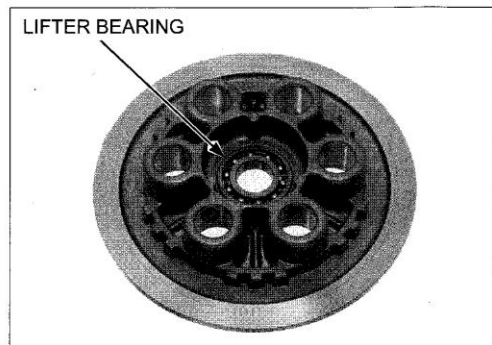

Drive in a new bearing into the pressure plate with its mark side facing up using the special tools.

TOOLS:

Driver
Attachment, 32 x 35 mm
Pilot, 17 mm

07749-0010000
07746-0010100
07746-0040400

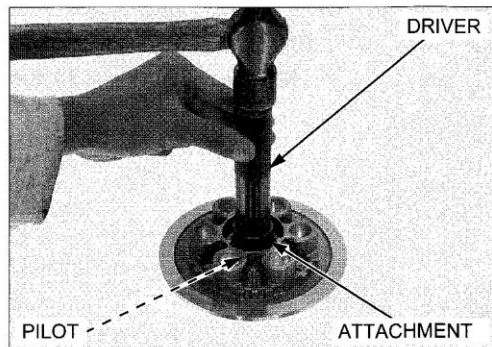

CLUTCH/GEARSHIFT LINKAGE

CLUTCH SPRING

Replace the clutch spring as a set.

Measure the clutch spring free length.

SERVICE LIMIT: 56.7 mm (2.23 in)

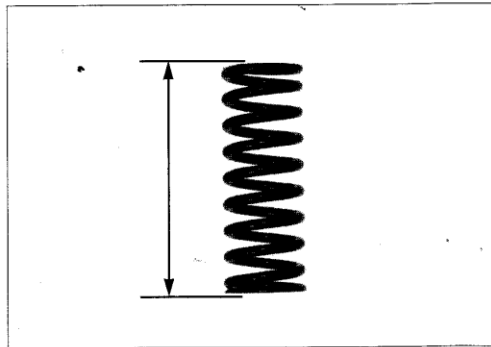

CLUTCH CENTER

Check the grooves of the clutch center for damage or wear caused by the clutch plate.

Replace the clutch center if necessary.

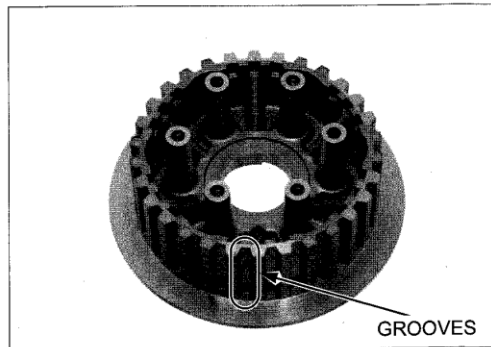

RUBBER DAMPER

Check the rubber dampers for deterioration, wear or damage.

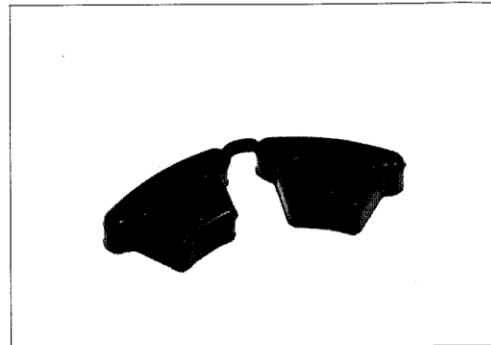

CLUTCH LIFTER ROD

Check the clutch lifter rod for bends or damage.

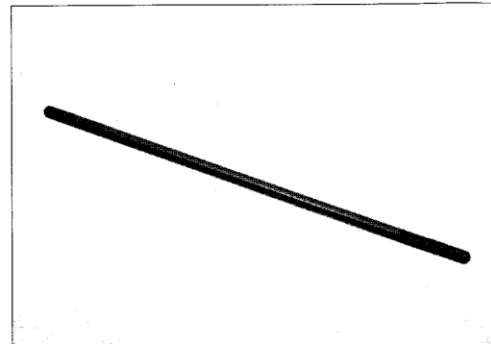

CLUTCH DISC

Replace the clutch discs and plates as a set.

Replace the clutch discs if they show signs of scoring or discoloration.

Measure the clutch disc thickness.

SERVICE LIMIT: 3.1 mm (0.12 in)

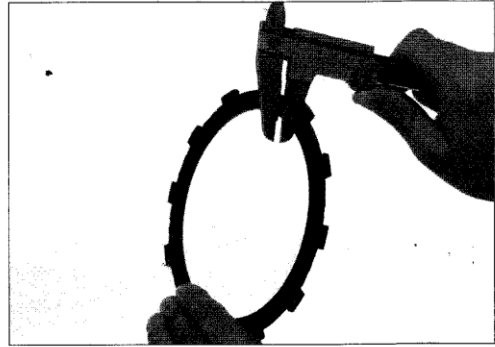

CLUTCH PLATE

Replace the clutch discs and plates as a set.

Check the clutch plate for discoloration

Check the clutch plate warpage on a surface plate using a feeler gauge.

SERVICE LIMIT: 0.30 mm (0.012 in)

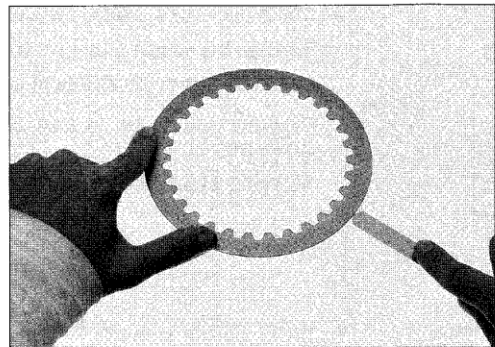

CLUTCH OUTER GUIDE

Check the clutch outer guide for damage or abnormal wear.

Measure the clutch outer guide I.D.

SERVICE LIMIT: 28.03 mm (1.104 in)

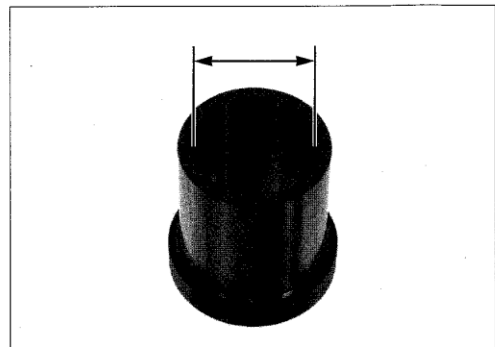

MAINSHAFT

Measure the mainshaft O.D. at the clutch outer guide.

SERVICE LIMIT: 27.97 mm (1.101 in)

Calculate the clutch outer guide-to-mainshaft clearance.

SERVICE LIMIT: 0.06 mm (0.002 in)

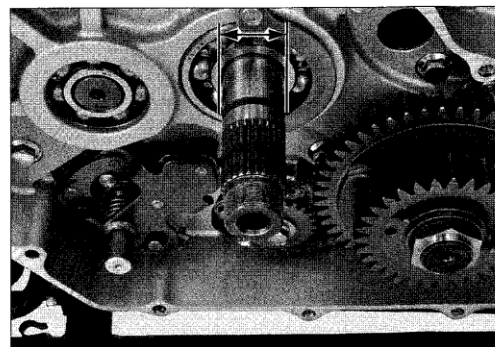

CLUTCH/GEARSHIFT LINKAGE

CLUTCH OUTER

Check the slots in the clutch outer for nicks, indentations or abnormal wear made by the clutch discs.

Measure the clutch outer I.D.

SERVICE LIMIT: 42.05 mm (1.656 in)

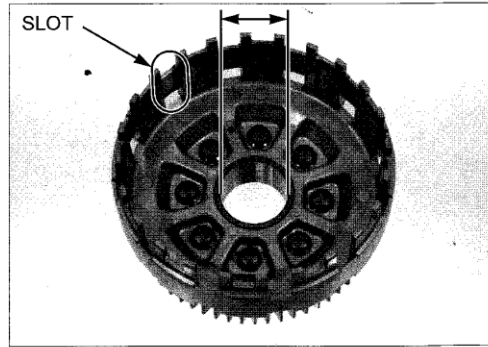

NEEDLE BEARING

Check the needle bearing for wear or damage.

Measure the needle bearing O.D.

SERVICE LIMIT: 41.98 mm (1.653 in)

Calculate the clutch outer-to-outer needle bearing clearance.

SERVICE LIMIT: 0.07 mm (0.003 in)

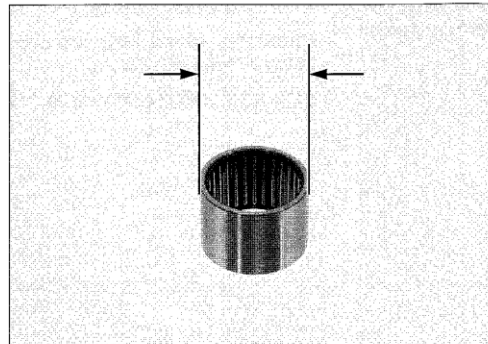

INSTALLATION

Apply engine oil to the clutch outer guide outer surface and install it to the mainshaft with the flange side facing the crankcase.

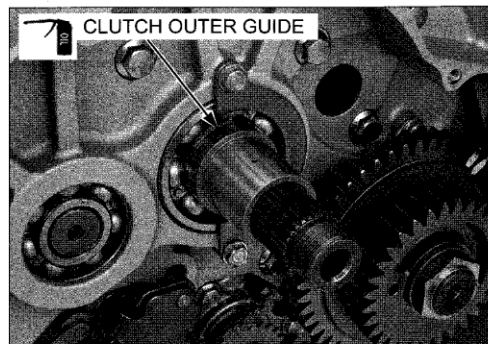

Apply engine oil to the outer guide washer entire surface and clutch outer needle bearing rotating area.

Install the outer guide washer and needle bearing to the clutch outer guide.

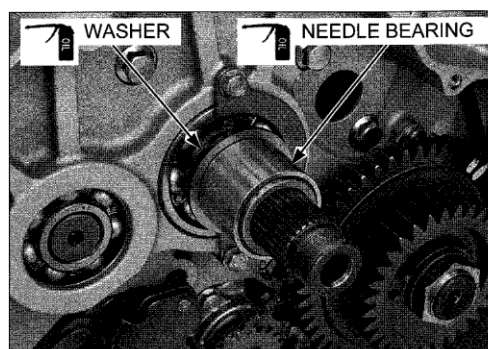

CLUTCH/GEARSHIFT LINKAGE

Install the clutch outer to the clutch outer needle bearing.

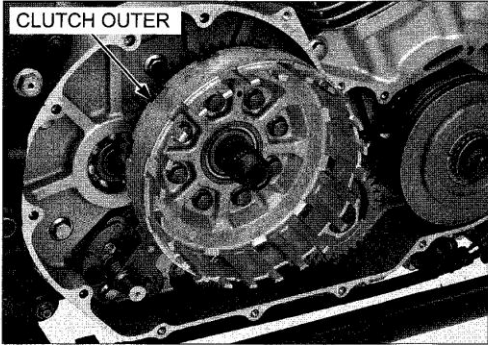

Install the rubber dampers to the clutch center.
Apply engine oil to the clutch center boss sliding area and install it to the clutch center.

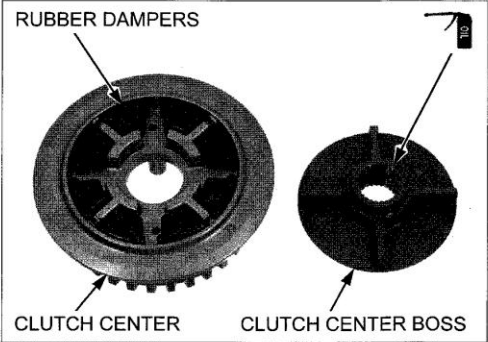

Install the clutch center assembly to the mainshaft.

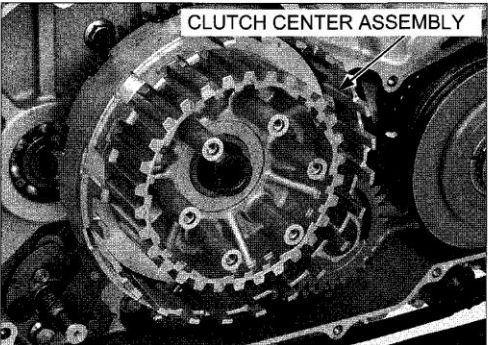

Install the washers.

- NOTE:**
- When installing the outside washer, install it with the "OUT" mark on the washer facing out.

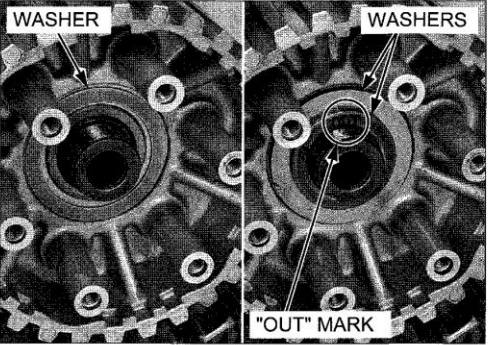

CLUTCH/GEARSHIFT LINKAGE

Apply engine oil to a new clutch center lock nut threads and seating surface.

Install the clutch center lock nut to the mainshaft.

Hold the clutch center with the special tool and tighten the lock nut to the specified torque.

TOOL:

Clutch center holder 07JMB-MN50302 or
07HGB-001010B
(plate) and
07HGB-001020B
(collar) (U.S.A. only)

TORQUE: 186 N·m (19.0 kgf·m, 137 lbf·ft)

Be careful not to damage the mainshaft threads.

Stake the clutch center lock nut into the mainshaft groove.

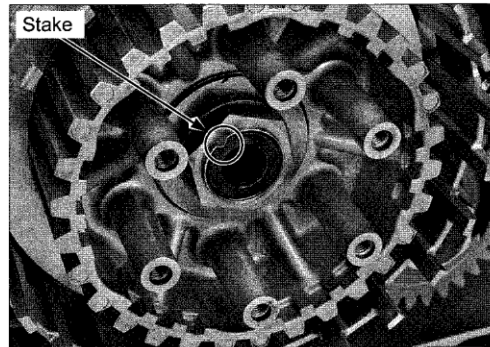
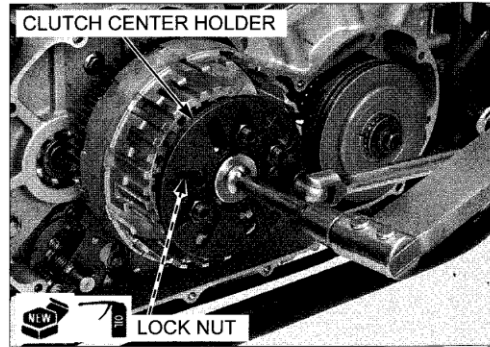

Apply engine oil to the clutch discs A and B entire surface.

Install clutch disc B.

Install the seven clutch plates and six discs A alternately, starting with the plate.

NOTE:

- When installing the clutch discs A and B to their original location as noted during removal.

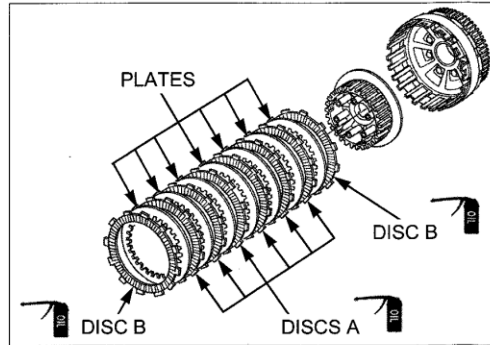

Install clutch disc B into the shallow slots of the clutch outer.

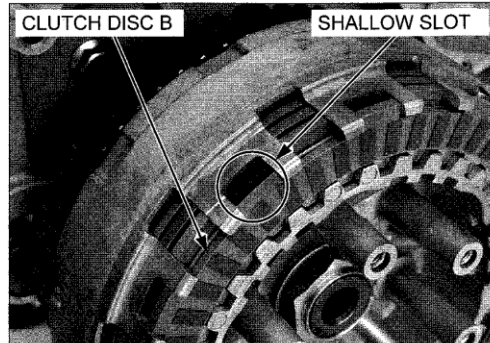

CLUTCH/GEARSHIFT LINKAGE

Install the clutch lifter rod into the mainshaft.

Apply engine oil to the clutch joint piece sliding surface and install it to the mainshaft.

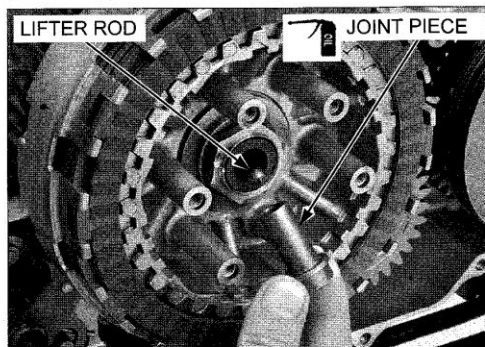

Install the clutch pressure plate, clutch springs and clutch pressure plate bolts.

Tighten the clutch pressure plate bolts to the specified torque in a crisscross pattern in several steps.

TORQUE: 12 N·m (1.2 kgf·m, 9 lbf·ft)

Install the right crankcase cover (page 11-23).

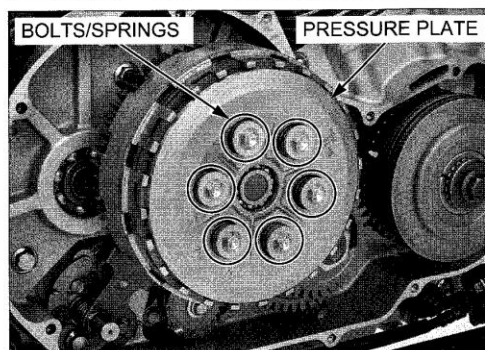

GEARSHIFT LINKAGE

REMOVAL

Remove the clutch (page 11-6).

Remove the bolt and gearshift arm from the gearshift spindle.

Clean off any dirt from the gearshift spindle serration.

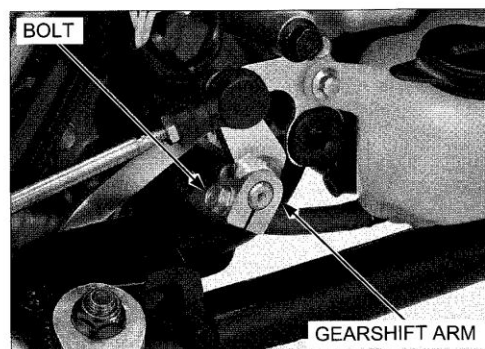

Remove the gearshift spindle assembly and thrust washer.

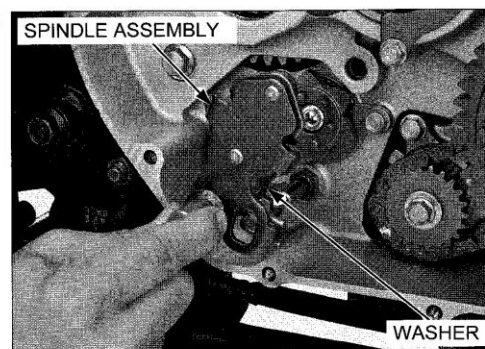

CLUTCH/GEARSHIFT LINKAGE

Remove the shift drum cam plate socket bolt and cam plate.
Remove the stopper arm pivot bolt, arm, washer and return spring.

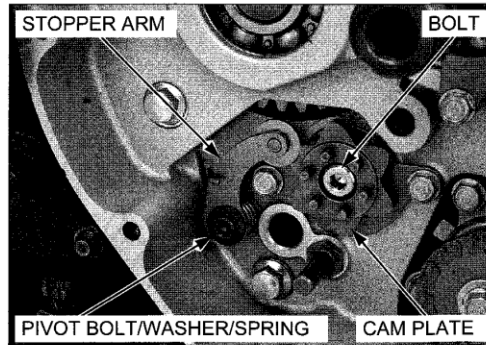

Remove the dowel pin from the shift drum.

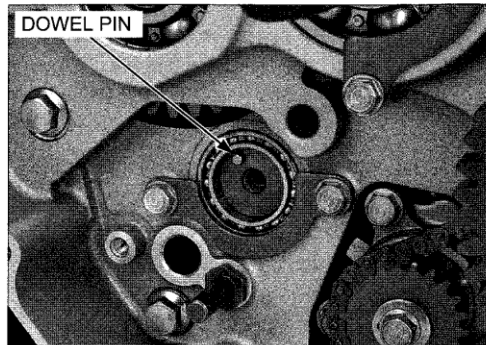

INSPECTION

Remove the bolt and stopper plate.

Check the gearshift spindle oil seal for deterioration or damage, replace it if necessary.

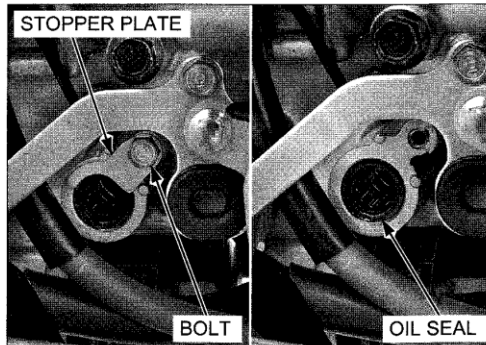

Check the gearshift spindle needle bearing for damage, replace it if necessary.

Installation is in the reverse order of removal.

NOTE:

- Install the oil seal with its marked side facing out.

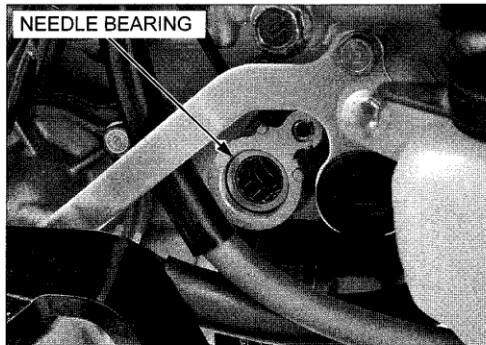

CLUTCH/GEARSHIFT LINKAGE

Check the gearshift spindle for bends.
Check the spindle plate for wear or damage.
Check the spindle return spring for fatigue or damage.

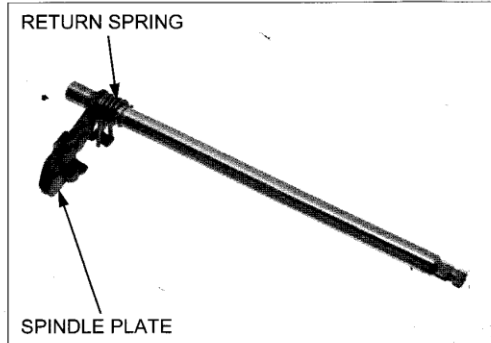

INSTALLATION

Install the dowel pin into the shift drum.

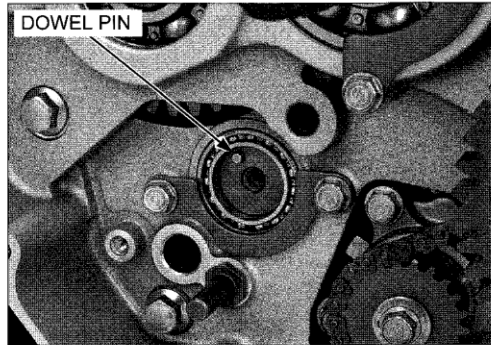

Install the return spring, washer, stopper arm and pivot bolt as shown.

Tighten the stopper arm pivot bolt to the specified torque.

TORQUE: 12 N·m (1.2 kgf·m, 9 lbf·ft)

Check the stopper arm for proper operation.

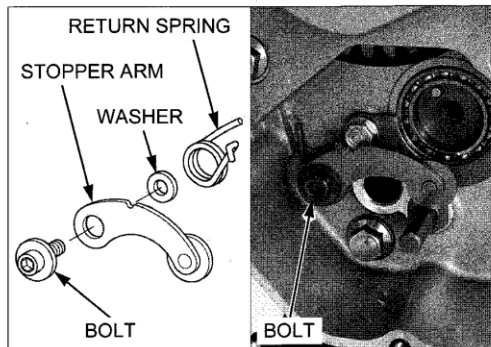

Lift the stopper arm with a screwdriver and install the cam plate by aligning its pin groove with the dowel pin.

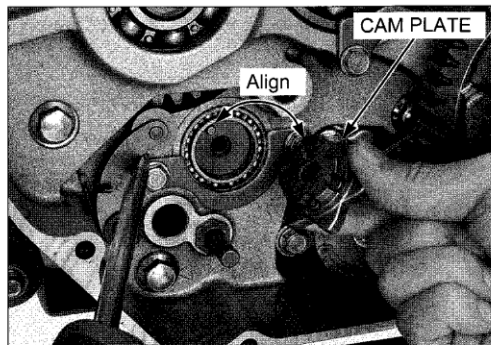

CLUTCH/GEARSHIFT LINKAGE

Apply locking agent to the shift drum cam plate socket bolt threads (page 1-16).

Install and tighten the socket bolt to the specified torque.

TORQUE: 23 N·m (2.3 kgf·m, 17 lbf·ft)

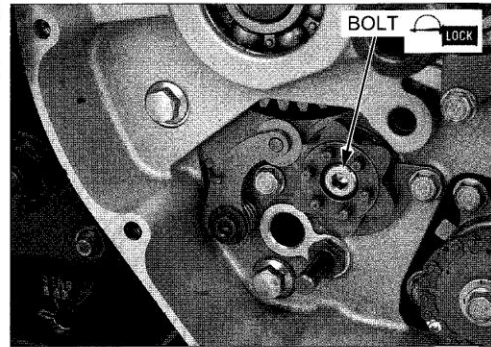

Install the thrust washer onto the gearshift spindle, and insert the spindle into the crankcase, aligning the return spring ends with the spring pin.

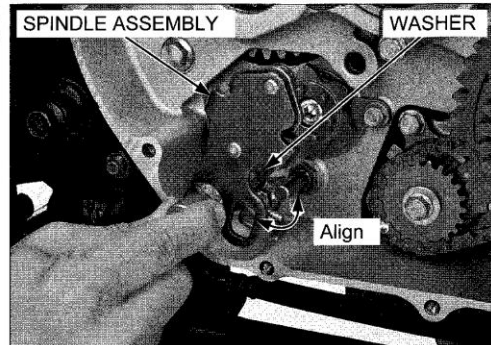

Install the gearshift arm onto the spindle by aligning its slit with the punch mark on the gearshift spindle. Tighten the gearshift arm bolt.

Install the clutch (page 11-12).

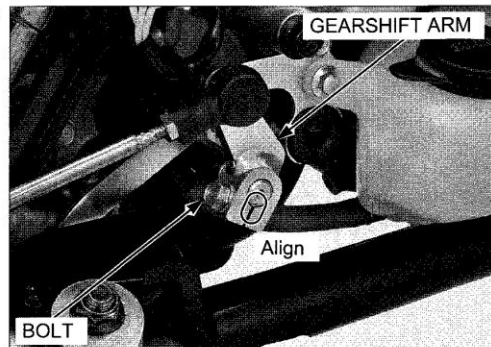

PRIMARY GEARS

PRIMARY DRIVE GEAR

REMOVAL

Remove the right crankcase cover (page 11-6).

Install the special tool between the primary drive gear and primary driven gear B as shown and loosen the primary drive gear bolt.

TOOL:

Gear holder, 2.5

**07724-0010100 or
07724-001A100
(U.S.A. only)**

Remove the following:

- Bolt
- Washer
- Primary drive gear assembly
- Special tool

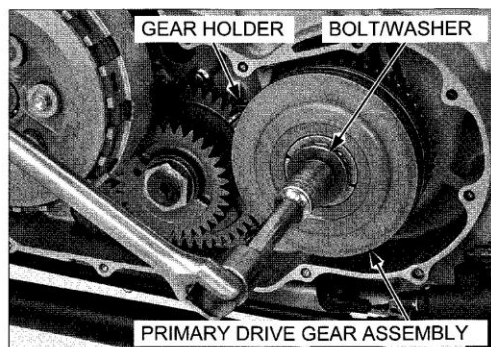

INSTALLATION

Install the primary drive gear assembly to the crankshaft, aligning the wide groove with the wide tooth.

Align the timing marks on the primary drive gear and primary driven gear B as shown.

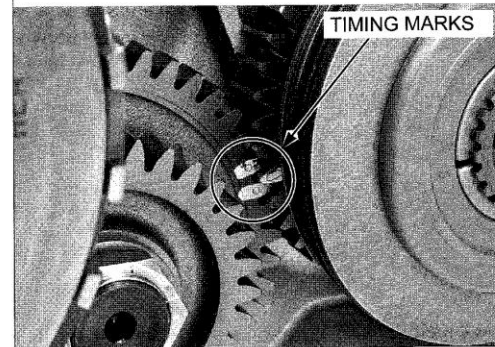
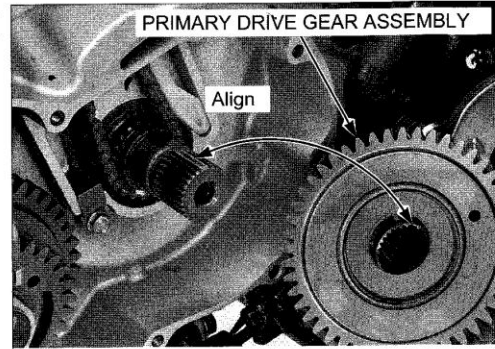

Apply engine oil to the primary drive gear bolt threads and primary drive gear thrust washer entire surface.

Install the washer and primary drive gear bolt.

Install the special tool between the primary drive gear and primary driven gear B as shown and tighten the primary drive gear bolt to the specified torque.

TOOL:

Gear holder, 2.5

07724-0010100 or
07724-001A100
(U.S.A. only)

TORQUE: 138 N·m (14.1 kgf·m, 102 lbf·ft)

Remove the special tool.

Install the right crankcase cover (page 11-23).

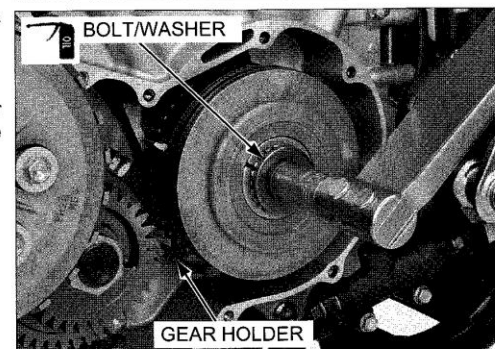

PRIMARY DRIVEN GEAR

REMOVAL

Remove the clutch (page 11-6).

Remove the primary drive gear assembly (page 11-18).

When the oil pump driven sprocket will be removed, loosen the driven sprocket bolt.

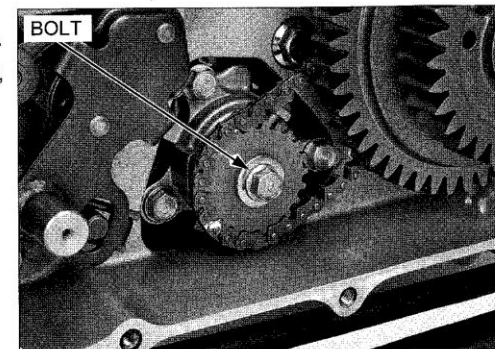

CLUTCH/GEARSHIFT LINKAGE

Be careful not to damage the rear balancer shaft threads. Unstake the primary driven gear lock nut.

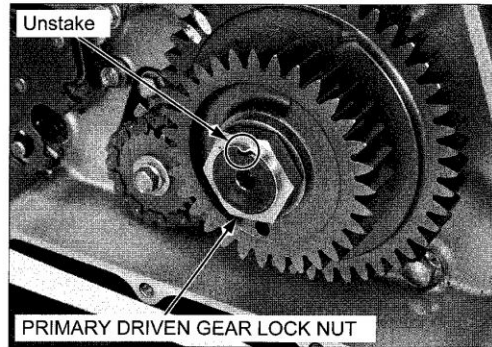

Temporarily install the clutch outer (page 11-12).
Install the special tool between the primary driven gear of the clutch outer and primary driven gear A as shown and loosen the primary driven gear lock nut.

TOOL:

Gear holder, 2.5

**07724-0010100 or
07724-001A100
(U.S.A. only)**

Remove the lock nut, spring washer, special tool and temporarily installed parts.

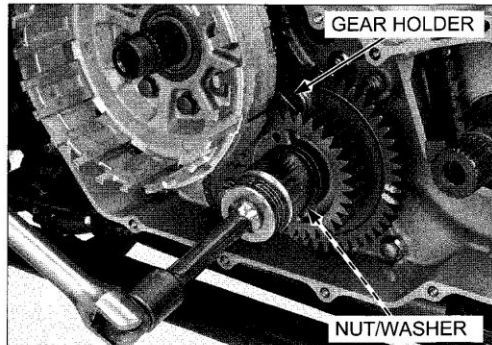

Remove the primary driven gear A.

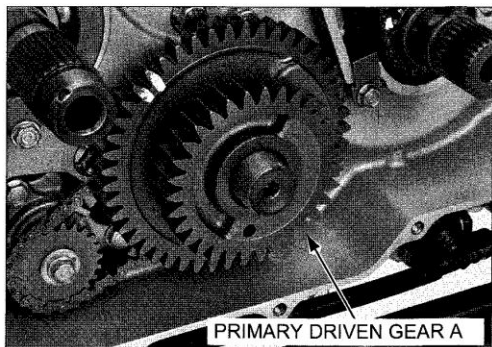

Remove the primary driven gear B.

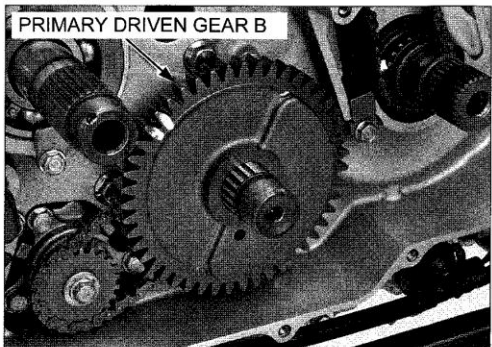

CLUTCH/GEARSHIFT LINKAGE

Remove the oil pump driven sprocket bolt and washer. Remove the oil pump driven sprocket, drive chain and drive sprocket as a set.

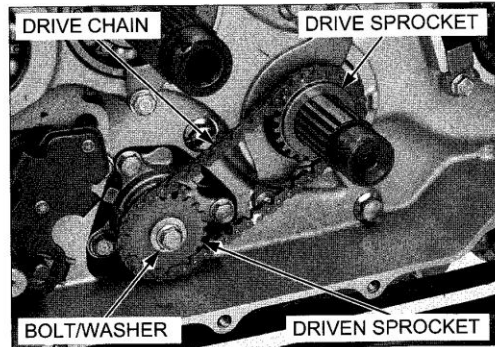

INSTALLATION

Install the oil pump drive sprocket to the rear balancer shaft, aligning the wide groove with the wide tooth.

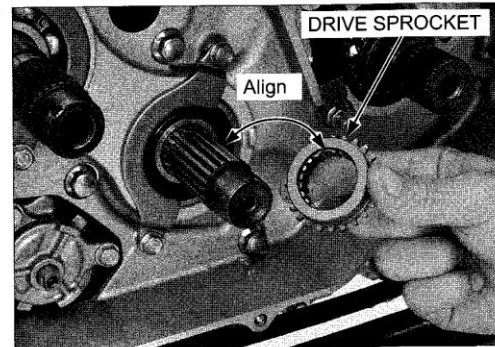

Install the drive chain and driven sprocket as a set with the "OUT" mark on the driven sprocket facing out.

NOTE:

- Align the flat surface of the oil pump driven sprocket hole and oil pump shaft end.

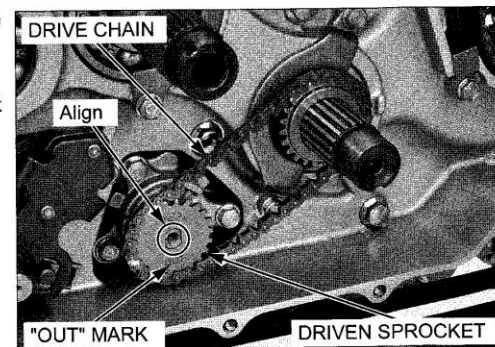

Install the washer to the oil pump driven sprocket bolt.

Apply locking agent to the oil pump driven sprocket bolt threads (page 1-16).

Install the oil pump driven sprocket bolt.

NOTE:

- Tighten the driven sprocket bolt to the specified torque after installing the primary driven gear.

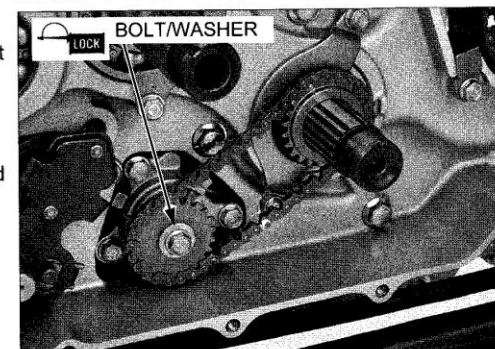

CLUTCH/GEARSHIFT LINKAGE

Install the primary driven gear B to the rear balancer shaft, aligning the wide groove with the wide tooth.

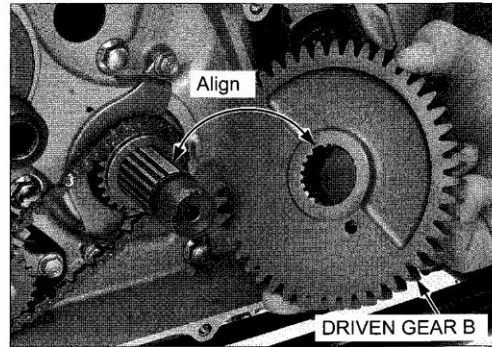

Install the primary driven gear A to the rear balancer shaft, aligning the wide groove with the wide tooth.

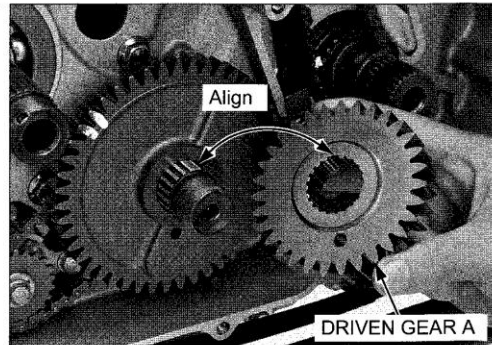

Install the spring washer to the rear balancer shaft with the "OUT" mark on the spring washer facing out.

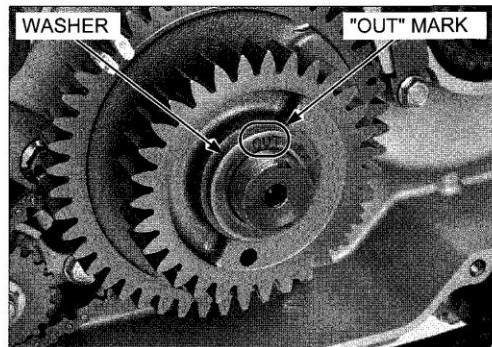

Temporarily install the clutch outer (page 11-12).

Apply engine oil to a new primary driven gear lock nut threads and seating surface, and install it.

Install the special tool between the primary driven gear of the clutch outer and primary driven gear A as shown and tighten the primary driven gear lock nut to the specified torque.

TOOL:

Gear holder, 2.5

07724-0010100 or
07724-001A100
(U.S.A. only)

TORQUE: 186 N·m (19.0 kgf·m, 137 lbf·ft)

Remove the special tool and temporarily installed parts.

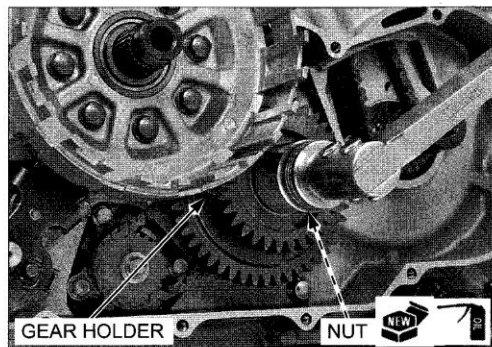

Be careful not to damage the rear balancer shaft threads.

Stake the primary driven gear lock nut into the rear balancer shaft groove.

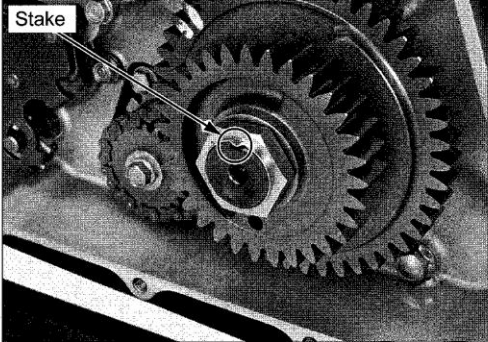

Tighten the oil pump driven sprocket bolt to the specified torque if it was removed.

TORQUE: 18 N·m (1.8 kgf·m, 13 lbf·ft)

Install the clutch (page 11-12).

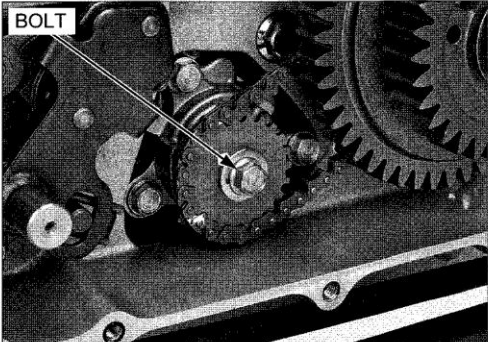

RIGHT CRANKCASE COVER INSTALLATION

Be careful not to damage the mating surfaces.

Clean the mating surfaces of the right crankcase and cover. Install the dowel pins.

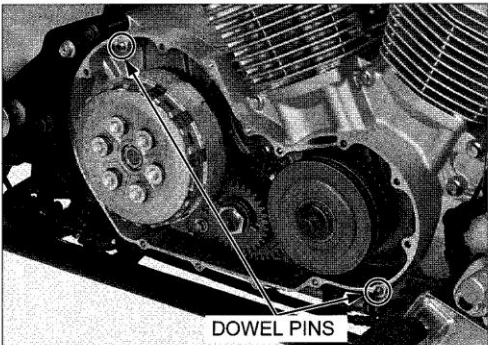

Apply liquid sealant (Three Bond 1207B or equivalent) to the right crankcase cover mating surface as shown.

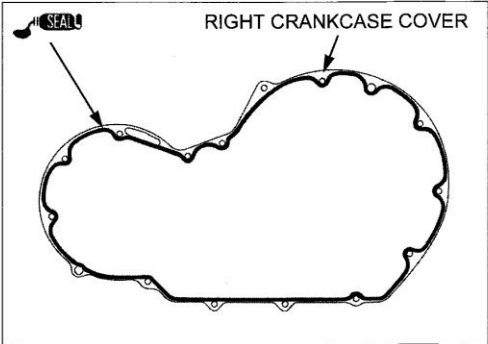

CLUTCH/GEARSHIFT LINKAGE

Install the right crankcase cover and bolts.

Tighten the bolts to the specified torque in a crisscross pattern in several steps.

TORQUE: 10 N·m (1.0 kgf·m, 7 lbf·ft)

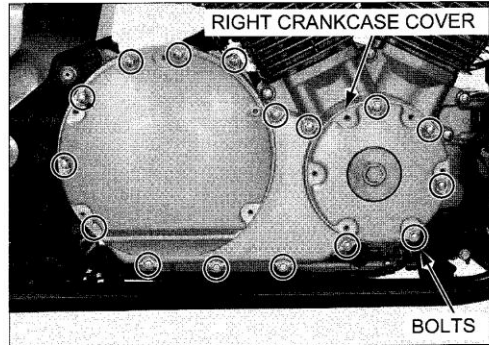

Install the timing hole cap cover and socket bolts.

Tighten the socket bolts to the specified torque.

TORQUE: 10 N·m (1.0 kgf·m, 7 lbf·ft)

Install the clutch cover and socket bolts.

Tighten the socket bolts to the specified torque.

TORQUE: 10 N·m (1.0 kgf·m, 7 lbf·ft)

Install the exhaust system (page 3-17).

Fill the recommended engine oil (page 4-13).

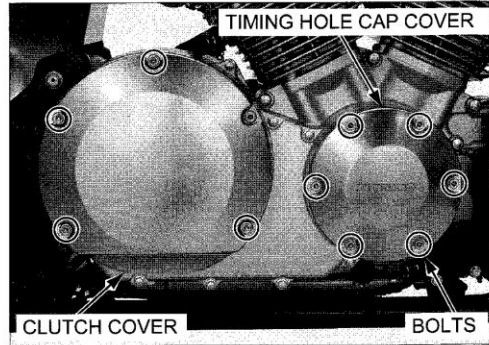

CLUTCH LIFTER ARM

REMOVAL

Remove the left crankcase rear cover (page 3-7).
Drain the coolant from the system (page 7-7).

Remove the clamp.

Remove the sidestand switch 2P (Gray) and neutral switch 1P (Black) connectors from the water pipe stay.

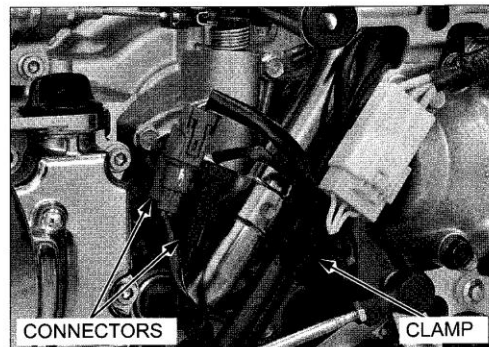

Loosen the water hose band screw and disconnect the water hose.

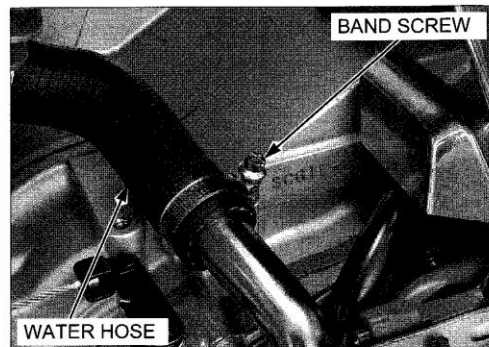

CLUTCH/GEARSHIFT LINKAGE

Remove the bolt and water pipe.

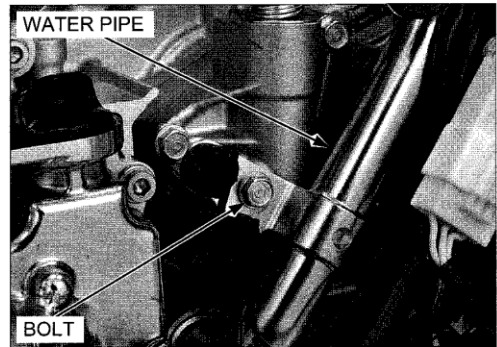

Remove the seal ring from the water pipe.

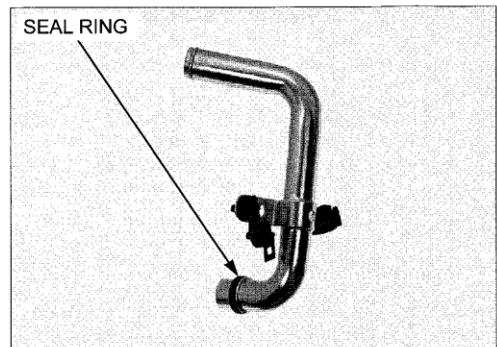

Remove the socket bolt and cable guide.
Disconnect the clutch cable from the clutch lifter arm.

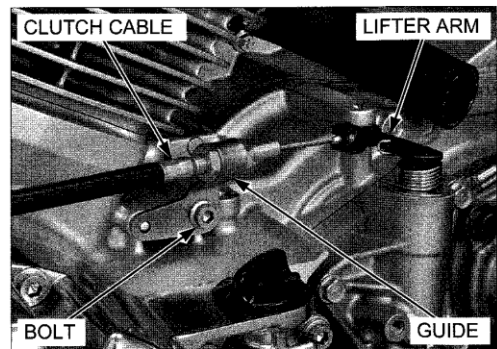

Remove the clutch lifter arm holder mounting bolts and disconnect the ground cable.
Remove the clutch lifter arm holder.

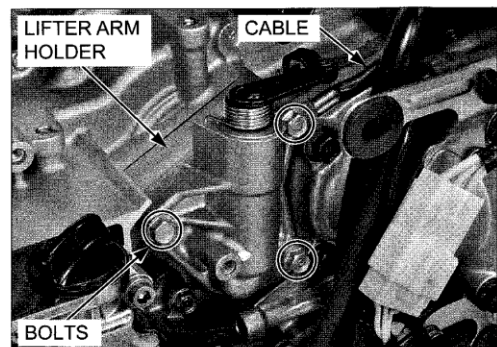

CLUTCH/GEARSHIFT LINKAGE

Remove the dowel pins.

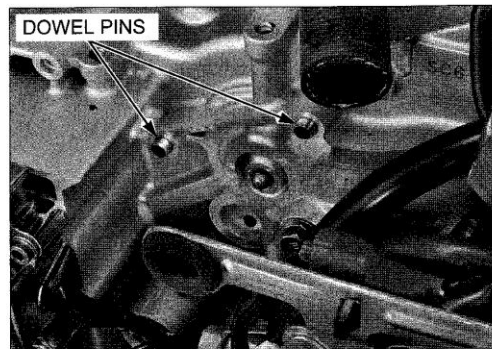

Remove the O-ring.

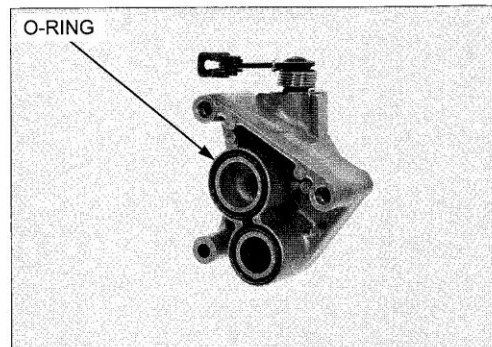

Turn the clutch lifter arm counterclockwise and remove the clutch lifter piece.

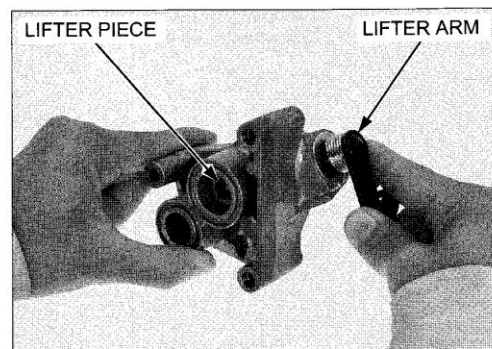

Remove the clutch lifter arm, return spring and washer from the clutch lifter arm holder.

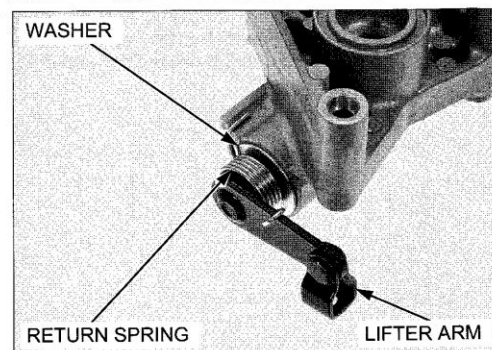

CLUTCH/GEARSHIFT LINKAGE

Check the dust seal and needle bearings in the clutch lifter arm holder for wear or damage.

Replace the clutch lifter arm holder if necessary.

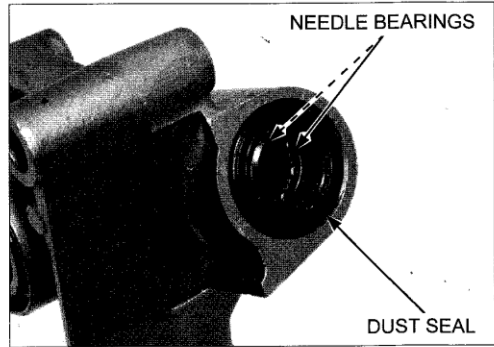

INSTALLATION

Apply engine oil to the clutch lifter arm sliding surface.

Install the return spring and washer onto the clutch lifter arm.

Install the clutch lifter arm into the clutch lifter arm holder.

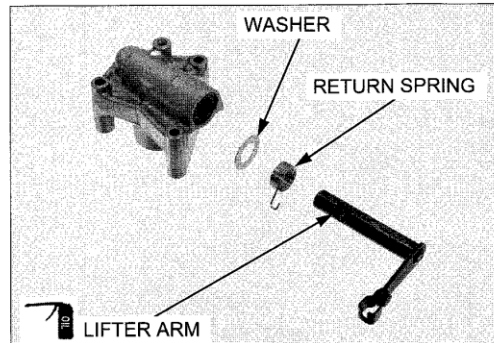

Hook the return spring ends to the clutch lifter arm and clutch lifter arm holder as shown.

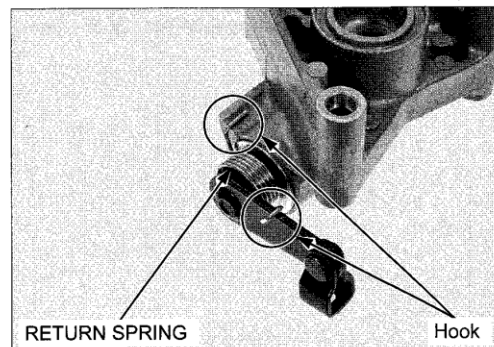

Apply engine oil to the clutch lifter piece sliding surface.

Turn the clutch lifter arm counterclockwise and install the clutch lifter piece into the clutch lifter arm holder.

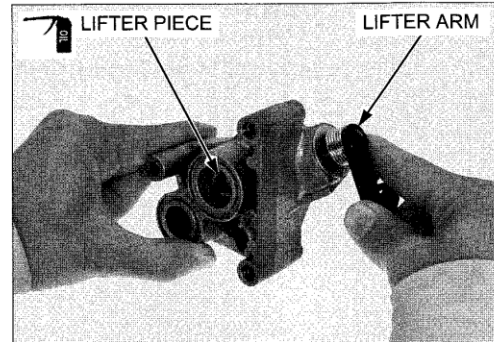

CLUTCH/GEARSHIFT LINKAGE

Apply engine oil to a new O-ring and install it to the clutch lifter arm holder groove.

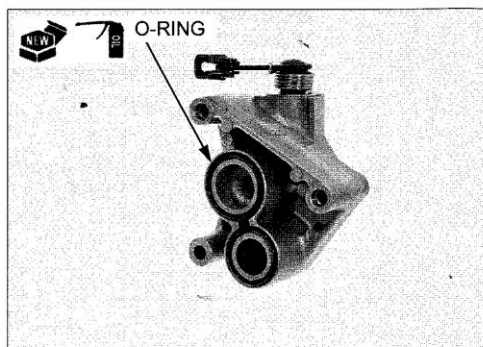

Install the dowel pins.

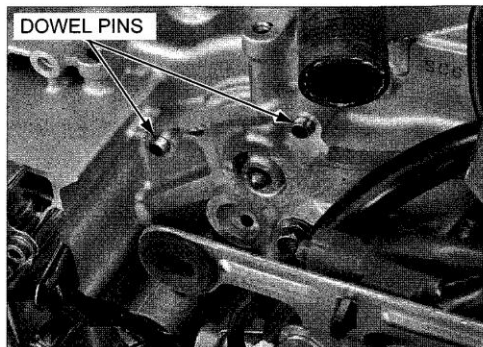

Install the clutch lifter arm holder and connect the ground cable by installing the clutch lifter arm holder mounting bolts and tighten them.

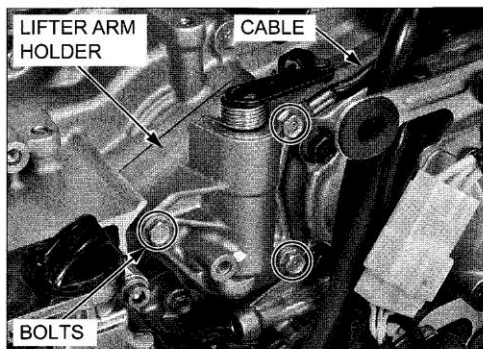

Connect the clutch cable to the clutch lifter arm.
Install the cable guide while aligning its hole with the tab of the left crankcase.
Install and tighten the socket bolt.

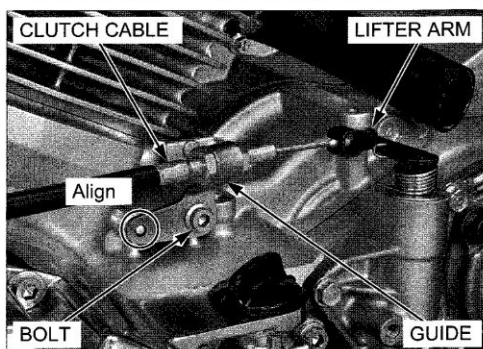

CLUTCH/GEARSHIFT LINKAGE

Install a new seal ring to the water pipe.
Install the water pipe to the water pump.

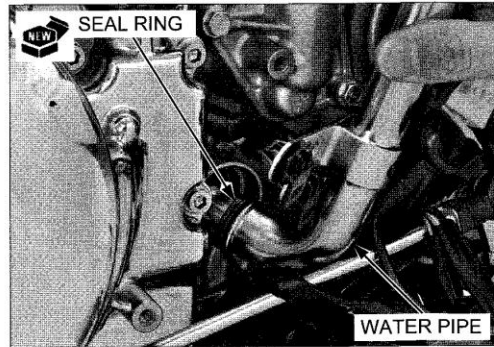

Install and tighten the bolt.

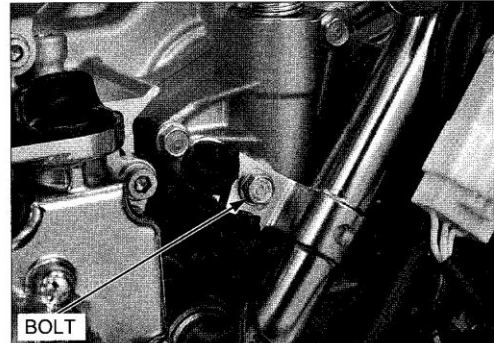

Connect the water hose and tighten the water hose band screw (page 7-15).

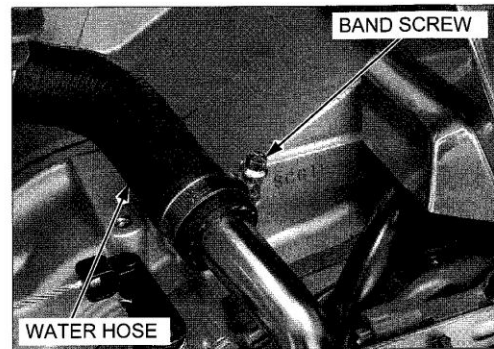

Install the neutral switch 1P (Black) and sidestand switch 2P (Gray) connectors to the water pipe stay.

Install the clamp.

Fill and bleed the cooling system (page 7-6).
Install the left crankcase rear cover (page 3-7).

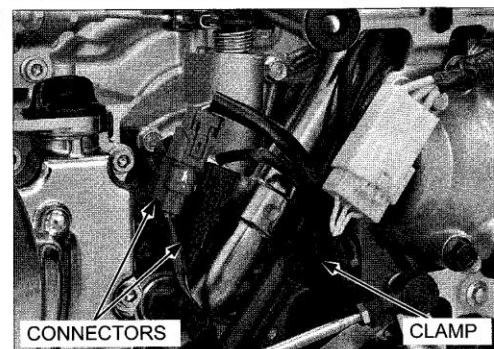

MEMO

)

)

)

)

)

)

)

)